

**Motic<sup>®</sup> Microscopes**

*Instruction Manual  
Bedienungsanleitung  
Manual de instrucciones*

*SMZ Series*

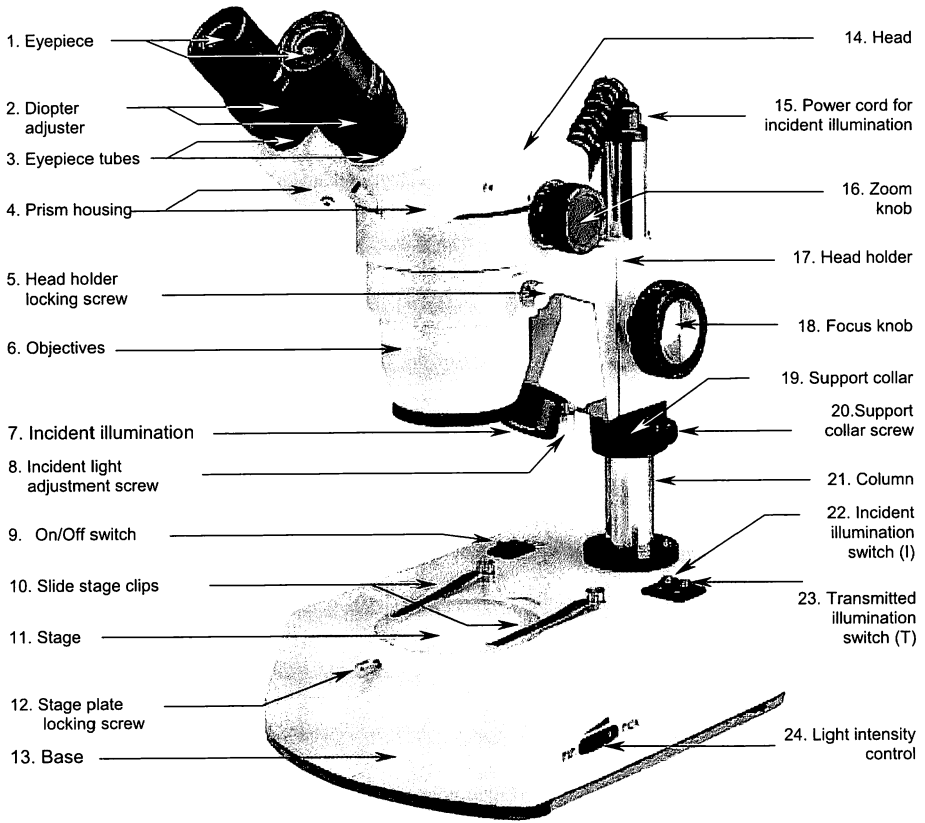

**SMZ-140-N2GG**

## **Introduction**

Thank you for your purchase of a Motic stereomicroscope. Motic stereomicroscopes are precision instruments, subjected to meticulous examination to reach you in perfect condition. Their design combines easy management and optimum functioning with minimum maintenance. The information contained in this manual is likely to go beyond what the average user needs to know to use the stereomicroscope, however, it is provided to answer any queries that may arise.

Stereomicroscopes are used to study three dimensional objects, examine small parts, or dissect biological specimens. They also permit the observation of slide specimens.

These instructions should be read carefully before operating the microscope. They will permit you to use your new stereomicroscope to its fullest capabilities. Terminology used to describe components and controls can be found in the diagram on page 2.

These instructions are based on the assembly and use of the SMZ-140-N2GG model with additional notes applying specifically for the other models in the series.

## **Unpacking**

All components of the stereomicroscope have been carefully packed to make sure they reach you in perfect condition. We recommend that you do not discard any packing containers in case you need to return the microscope or store it for long periods of time; or should it become necessary to transport it to a technical service for any repair, or maintenance procedure.

The box should contain the following components:

- SMZ-140-N2GG (Binocular): An illuminated base with a pole for a moveable head, also illuminated. A black and white opaque stage, a binocular head with an eyepiece, eyepiece protectors, a frosted glass stage, a blue filter, a protective cover and a 1,5mm hexagonal key.
- SMZ-143-N2GG (Trinocular): An illuminated base with a pole for a moveable head, also illuminated. A black and white opaque stage, a trinocular head with an eyepiece, an adapter for a photographic camera, and one for a CCD camera, eyepiece protectors, a frosted glass stage, a blue filter, a protective cover and a 1,5mm hexagonal key.

**Remove and handle all components of the microscope with extreme care.**

**Avoid touching the lenses of the optical elements and keep clear of contact with dust, water or other contaminating agents, as they could stain, or damage the lens surface and affect the quality of the image.**

## Assembly

All the steps described for the assembly of the stereomicroscope must be undertaken with extreme care, and without forcing the placement of the distinct parts and elements of the stereomicroscope.

- A. Place the base of the microscope (13) upright on a flat, stable and clean surface.
- B. Ensure that the head holder locking screw (Fig. 1) is tight.
- C. Loosen the head holder locking screw (5) and place head (14) in head holder (17) with extreme care.
- D. Tighten screw.
- E. Connect incident illumination to power cord (15) located at the upper part of the column (21).

**WARNING: Before connecting the stereomicroscope to a power source, always check that the voltage coincides with that of the stereo microscope.**

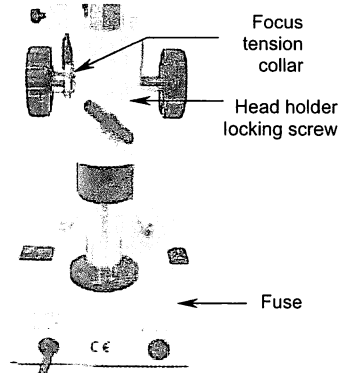

Fig. 1

## Operation

### A. Starting Up

The stereomicroscope has two stages. One is frosted glass and is used for the observation of microscope slides or samples that are thin or transparent, such as leaves, insect wings, etc. The black and white stage is used for non transparent objects, or for dissection. For best contrast, choose the side of the stage to use.

**Warning:** Transmitted illumination can ONLY be used with the frosted glass stage. THE HEAT GENERATED BY THE TRANSMITTED ILLUMINATION CAN MELT OR DAMAGE THE BLACK AND WHITE STAGE. SUCH DAMAGE WOULD NOT BE INCLUDED UNDER WARRANTY.

1. Changing the stage.
  - a. Loosen the stage plate locking screw (12) and remove the stage (11).
  - b. If wishing to use the glass stage, insert the blue filter in the centre of the base with the frosted surface facing down.
  - c. Place the glass stage with the frosted surface, again, facing down.
  - d. Retighten the stage plate locking screw.
2. Before connecting the stereomicroscope to a power source, adjust light intensity to its minimum (24). This must be repeated every time the stereomicroscope is turned on or off, to prolong the life of the bulb.

Three light switches are located on the base of the microscope.

MAIN : The principal switch, which turns the whole unit on or off.  
I : Turns incident light on or off. (Illumination from above)  
T : Turns transmitted illumination on or off (illumination from below)

3. Press the principal switch (9) to an ON position "I".
4. Press the incident illumination (22) or transmitted illumination (23) or both at the same time "I" or "II", according to your needs in observing the sample.
5. Light intensity should be adjusted according to the objective used, or the type of sample observed.
6. The angle of incident illumination can be adjusted by using the adjustment screw (8) that can be used to vary the orientation of the lens.

#### B. Interpupillary adjustment.

1. Looking through the eyepiece (1), move the eyepiece tubes (3) by taking hold of the prism housing (4) and moving out, or inwards.
2. Interpupillary distance is correct when the two fields of view viewed through both eyepieces appear complete, and are unified into one.
3. Interpupillary distance should be adjusted for each new user.

#### C. Focussing

1. Turn the zoom knob (16) to the lowest magnification 1X.
2. Place a flat object or a microscope slide on the centre of the stage (11).
3. Turn focussing knobs (18) to mid-focus range.
4. The head holder (17) is mounted on a column (21), on which it can be moved up or down, depending on the size of the object to be focussed on.
  - a. Support head holder (17) with one hand without touching any lens, and with the other, loosen the screw (20) on the support collar (19). The head holder can then be slid to the base (13).
  - b. Without letting go of the head, loosen the head holder locking screw. (Fig. 1).
  - c. While looking through the eyepiece, move the head holder up or down until the object appears in focus.
  - d. Tighten the head holder locking screw. Do not let go of the head yet.
  - e. Slide the security collar up to the head holder, and tighten the support collar screw. The head can then be released.
  - f. It is not necessary to adjust the head every time the sample is changed, only when it appears out of focus.
5. Adjust the focus knobs, (18) until the image appears sharp.

#### C. Diopter adjustment.

Diopter adjustment collars are located on the eyepiece tubes. Their normal position is when the lower part of the collar is aligned with the sign marked on the eyepiece tube.

For differences in eyesight:

1. Using only the right eye, look through the right eyepiece (1) and adjust focus.
2. Next, using the left eye, look through the eyepiece and adjust the focus by turning the diopter adjuster (2) located on the left-hand tube (3) until the image appears sharp. Do not use the focus knobs to adjust focus (18).

D. Changing magnification.

1. Turn the zoom control (16) to the highest magnification, 4X.
2. Although the stereomicroscope has been parfocalised, focus will have to be adjusted as the objectives of a low magnification offer a more profound field of view. The profundity of the field is the capacity to focus on different points on different levels.
3. Once the image is in focus with the higher magnification objectives it is not necessary to adjust the focus when lower magnification objectives are used.

**Adapting a photographic, or a video camera (Only for model SMZ-143)**

The model SMZ-143 comes equipped with a vertical image port on the head for the installation of a photographic reflex type camera, or video camera, using the corresponding adapters.

At the back of the head there is a selection lever (Fig. 2) that transmits the image to the vertical port. In an extended position the image is transmitted to the vertical port, but the image cannot be seen by the right eyepiece.

- A. To adapt a photographic camera an adapter tube is needed. This tube includes 2X lenses to balance the correct parfocality between the images received by the binocular and vertical ports. This balance can be achieved providing that the parfocality has been adjusted correctly, as described in point "D. Changing magnification" in this manual.

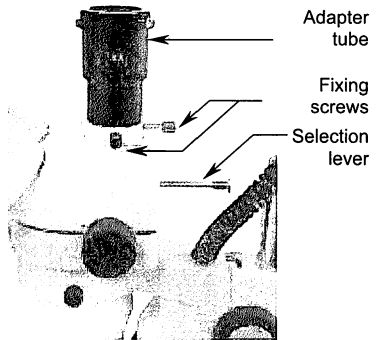

Fig. 2

The adapter tube has a T type thread at one end where adapter mounts of all types can be adapted for all reflex camera brand names on the market.

**NB:** The T type adapter mount is not included as it is an item specific to each brand of camera on the market

1. To connect the camera to the microscope, first remove the front lens of the camera, and place the corresponding T mount. Screw on the adapter tube provided, onto the mount of the camera.
2. Loosen the knurled screw (Fig.2), situated on the side of the vertical port on the head, sufficiently enough to remove the protective cover.
3. Insert the adapter tube with the camera already mounted on the vertical port. If it does not insert easily, unscrew the knurled screw until the adapter tube fits perfectly.
4. Re-tighten the knurled screw, so that the camera is secure.
5. Operate the camera according to manufacturers instructions.

- B. To adapt a video camera an adapter tube is needed. This adapter tube includes 0.5X lenses that correct the parfocality of images, from both binocular and vertical ports, shown on the TV monitor. This is providing that parfocality has been correctly adjusted according to the steps followed in point "D. Changing magnification" in this manual.

The adapter tube is provided with a "C" thread, and a "CS" ring which can adapt different kinds of video camera.

To connect the camera to the microscope, screw the adapter tube to the video camera.

1. Loosen the knurled screw (Fig.2) on the side of the vertical port of the head sufficiently enough to remove the protective cover.
2. Insert the adapter tube with the camera already mounted on the vertical port, as shown in figure 4. If it does not insert easily, unscrew the knurled screw until the adapter tube fits perfectly.
3. Re-tighten the knurled screw firmly, so that the camera is secure.
4. Operate the camera according to manufacturers instructions.

If the image on the monitor appears out of focus when the objective is changed, it is possible that the CS mount is responsible. Place, or remove it, according to the procedure to obtain parfocality.

## **Maintenance**

**WARNING:** FOR YOUR OWN SAFETY SWITCH OFF AND DISCONNECT THE MICROSCOPE FROM ANY ELECTRICAL SOURCE BEFORE ATTEMPTING ANY MAINTENANCE PROCEDURE TO AVOID THE RISK OF ELECTROCUTION.

CONSULT YOUR DISTRIBUTOR IF ANY REPAIR OR MAINTENANCE PROCEDURE IS REQUIRED TO YOUR MICROSCOPE THAT DOES NOT APPEAR IN THIS INSTRUCTION MANUAL.

### A. Optical maintenance.

Do not attempt to disassemble any optical component. For any repair work not specified in this manual, consult the technical service responsible in your area.

Before cleaning the lens surface, remove dust with a brush specifically for lenses, or with low pressure compressed air, found in any photography shop.

1. Cleaning the eyepiece
  - a. Do not remove the eyepiece (1) from the eyepiece tube (3).
  - b. Clean the external surface dampening the lens with breath.
  - c. Afterwards, dry the lens with special lens paper. Dry in circular movements from the centre of the lens, outwards. Do not wipe the lens when already dry, as they scratch easily.
2. Cleaning the objectives.
  - a. Do not remove objectives from the microscope.
  - b. Only clean the surface area. Use a soft cotton cloth dampened slightly with Xylene. Dry the lens afterwards with the same cloth.

## B. Electrical maintenance.

### 1. Changing the bulb.

- Changing the transmitted illumination bulb.
  - a. Rest the stereomicroscope on its side being extremely careful, especially with the eyepiece (1) and the stage (11).
  - b. Unscrew the 4 screws indicated (Fig. 3) and open the cap on the base.
  - c. With a cloth, carefully pull out the bulb disconnect it from the socket.
  - d. Do not touch the new bulb with your hands. Use a clean cloth to insert the pins of the bulb into the socket.
  - e. If the bulb is accidentally touched with bare hands, it must be cleaned, as this could affect the transmission of light, and life span of the bulb.
  - f. Close the cover on the base and screw down firmly.
- Changing incident illumination bulb.
  - a. Unscrew the illuminator protector tube (7), turning it anti-clockwise, and removing the tube from that of the lenses.
  - b. With a cloth carefully pull out the bulb to disconnect it from the socket.
  - g. If the bulb is accidentally touched with bare hands, it must be cleaned, as this could affect the transmission of light, and life span of the bulb.
  - c. Replace illuminator lens tube, turning in clockwise, and screwing in the protector tube.

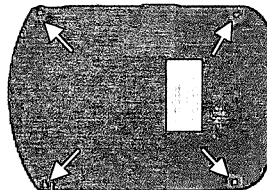

Fig. 3

### 3. Changing the fuse.

- a. With a flat screwdriver, lightly press on the slot of the fuse holder cover (Fig. 1) and turn 1/4 in the direction of the arrow marked.
- b. Release pressure and completely remove the loosened cover.
- c. Remove the fuse from the removed cover, and insert the new one, ensure that it is 0.5 Amps.
- d. Insert the cover.
- e. Repeat step (a.) but turning 1/4 in the opposite direction to the arrow. The cover must be firmly closed.



C. Mechanical maintenance

1. Adjusting the tension of the focus.

Tension comes pre-adjusted by the factory. The best point of tension is that which permits the focus knobs to move as loosely as possible, without the head sliding down with its own weight.

The tension adjustment collar for focussing (Fig.1) is situated between the focussing knob (18) and the head holder (17).

- a. Loosen the screw located in the collar hole with the 2mm hexagonal key.
- b. To increase the tension, turn the collar anti-clockwise; to decrease it, turn the collar clockwise.
- c. Re-tighten the hexagonal key.

**Troubleshooting:**

**ELECTRICAL PROBLEMS**

<b>PROBLEM</b>	<b>CAUSE</b>	<b>SOLUTION</b>
The bulb does not work.	Outlet inoperative. Cable not connected. Bulb burned out. Fuse blown. Wrong Bulb.	Have it repaired by a qualified specialised technician. Connect the cable to the power source. Replace bulb. Replace fuse. Replace with appropriate bulb.
Bulb has short life span.	Very high voltage.	Reduce light intensity to the minimum before turning on or off the stereomicroscope.
Bulb burns out immediately.	Wrong bulb.	Replace with the appropriate bulb.
Bulb flickers.	The bulb is not inserted correctly into socket. Bulb on the point of burning out. Fuse cover badly closed. Bad connection with power source.	Insert bulb correctly. Replace bulb. Close correctly. Have repaired by a qualified specialised technician.
Fuse blown quickly	Wrong fuse.	Replace with appropriate fuse.
Fuse blown instantly	Short circuit.	Have repaired by a qualified specialised technician.

**IMAGE QUALITY**

<b>PROBLEM</b>	<b>CAUSE</b>	<b>SOLUTION</b>
Poor resolution.	Eyepieces dirty. Objectives dirty.	Clean eyepieces. Clean objectives.
Spots, or stains in field of view.	Eyepieces dirty.	Clean eyepieces.
* NB. Stains in field of view may also be attributed to dirt on the inside of the eyepiece. It is recommended therefore that the lens be cleaned by a recognised service technician.		

**MECHANICAL PROBLEMS**

<b>PROBLEM</b>	<b>CAUSE</b>	<b>SOLUTION</b>
It does not stay in focus.	The head drops down.	Adjust the tension of the coarse focus knob.

### **Moving the microscope**

- If possible, avoid moving the stereomicroscope.
- Carry the stereomicroscope in both hands. One hand should hold the stereomicroscope column (21), and the other should support it under the base (13).
- Maintain the stereomicroscope in a vertical position.

### **Repair**

If the stereomicroscope needs repairing, or revision by authorised personnel, we would recommend that it be stored in its polystyrene box and returned to the distributor. Attach a note with a description of the problem, or details of the required revision.

### **Warranty**

All MOTIC microscopes are warranted against any manufacturing defect for a 5 year period. Damage occurring by any unauthorised repair work, or occurring through misuse or modification of the microscope will not be included under the conditions of the warranty. Bulbs and fuses are not under warranty.

The warranty service is provided by MOTIC, or its authorised distributors. Defective products will be repaired free of charge when returned to MOTIC, or one of its distributors. Transport costs will be covered by the purchaser.

**OWING TO POSSIBLE MODIFICATIONS AND IMPROVEMENTS IN THEIR MANUFACTURE, CHANGES MAY OCCUR TO STEREOMICROSCOPES WITHOUT PRIOR NOTICE.**